

11 Modifications of Basic Clause Patterns

KEY CONCEPTS

Transformational grammar: deep structure, surface structure, transformations

Movement

Assignment of semantic roles

Deletion

Insertion

Discourse functions of modified clauses

INTRODUCTION

In our chapter on Basic Clause Patterns, we dealt with simple sentences, that is, sentences that contain only one clause, consisting of an NP subject, AUX, and VP predicate. In this chapter we examine sentences in which elements of simple sentences are moved from their canonical positions, are understood even though no words are present, and in which certain kinds of elements are inserted into clauses to fulfill certain functions. In order to explain the phenomena of movement, deletion, and insertion, we will introduce elements from a theory of syntax called **transformational grammar**. Specifically we will distinguish between a clause's **deep structure** (DS), the nature of which we will make clear later, and its **surface structure** (SS), i.e., the form it actually occurs in. We will also introduce **transformational rules**, i.e., the rules that move, delete, and insert linguistic elements in the journey from deep to surface structure. As we go along we will also discuss the discourse functions of the sentence types we introduce. (To follow the development of one strand of transformational grammar see Carnie 2007; Chomsky 1964; Culicover 1976, 1982; Radford 1981, 1988, 1997a, 1997b.)

MOVEMENT

We begin by examining sentence variations that involve the movement of elements from one position to another in a clause. We begin with one of the simplest of these variations—**particle movement**.

Particle movement

Particles are words such as *up* or *over* that may occur as prepositions when they take their own NP objects or as adverbs when they modify Vs or VPs. When these words combine with a verb to create an idiomatic unit, they are called **particles**. For example, combining *look* and *up* creates the **phrasal verb** *look*

up in the following sentences:

- (1) a. Bill looked up the number.
 b. Bill looked the number up.

These two sentences differ only in the position of the particle *up*. In the first it occurs between the verb and the object; in the second, to the right of the object. Both sentences contain the same words, and the phrases, particularly the NPs, perform the same grammatical functions in both: *Bill* is the subject; *the number* is the direct object. Moreover, the two sentences are synonymous. By this we mean specifically that the semantic roles (see our chapter on Basic Clause Patterns) assigned to the NPs are the same in both sentences. *Bill* is the Agent and *the number* is the Theme. As native speakers we can assert these facts with certainty, and expect universal agreement among English speakers. Because knowledge of the relationships between sentence pairs like these is part of every native English speaker's competence, it must be expressed in a grammar. At issue is how to do this.

We can assign the following analyses to sentences (1a,b)

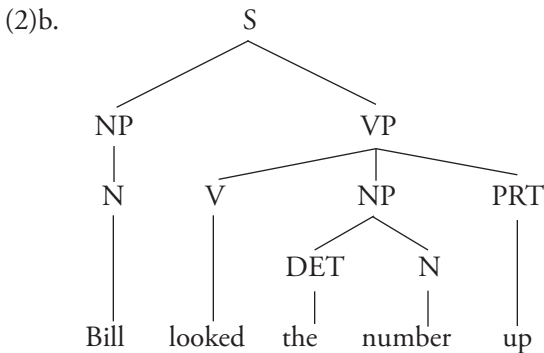
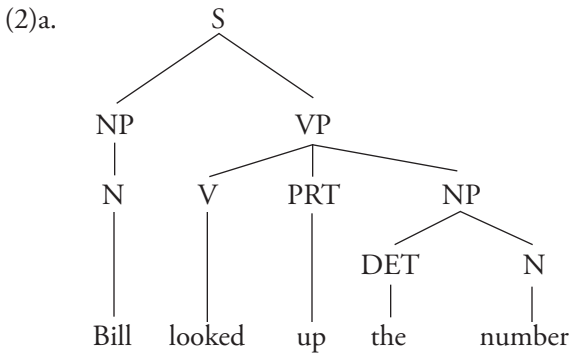

These structures can be generated by the phrase structure rules:

- (3) a. $S \longrightarrow NP \text{ AUX VP}$ (i.e., S consists of NP, AUX, and VP)
 b. $VP \longrightarrow V \text{ PRT NP}$ (cf. tree (2a))
 c. $VP \longrightarrow V \text{ NP PRT}$ (cf. tree (2b))

Now, if the two sentences (1a, b) can be created (“generated”) by the rules in (3), why can’t we declare victory, leave well enough alone and go on to the next topic? The answer is that while the two rules (3b, c) might be just coincidentally similar, speakers of English know that the sentences they represent are related, that they are variant forms of each other. If we assume that a goal of our grammar is to represent native speakers’ linguistic knowledge—their linguistic **competence**—then we have to represent the relationship between pairs of sentence like (1a,b). We will adopt a strategy similar to the one we adopted in phonology and morphology, namely that variant forms (e.g., allophones and allomorphs) are assumed to be different representations or manifestations of the same abstract form. So, (1a,b) are different surface manifestations of an abstract structure that they have in common, much as the allomorphs /s/, /z/, and /əz/ are manifestations of the morpheme {-s}.

This common abstract form is the **deep structure**. The actual strings of words and their structural organizations are the **surface structures**. The deep structure and surface structure of a sentence are connected by transformational rules, or just **transformations**, which move, delete, or insert items.

We will make a few assumptions about deep structures. First, they are created by phrase structure rules (PSRs), like those in (3). Second, elements that are semantically closely related must be syntactically closely related in DS. So, for example, in particle sentences such as (1a,b), because the particle and verb are closely associated semantically, they must be closely associated in DS. Consequently, we should prefer *look up the number* rather than *look the number up* as the DS arrangement of words. Third, as we will discuss in greater depth later, if a verb assigns a semantic role to an NP, then that NP must be in the same clause as the verb.

We have now argued that (2a) represents the DS of both (1a, b). The surface structure of (1a) is identical in all relevant respects to its deep structure. The surface structure of (1b) is slightly different from its deep structure, specifically regarding the position of the particle. We account for this slight difference by hypothesizing a transformation (called **Particle Movement (PM)**) which moves a particle from its deep structure position beside its verb, places it to the right of the direct object, and attaches it to the VP. This

yields the surface structure (2b).

The transformational approach has the advantage of expressing, by the common deep structure, native speakers' knowledge that pairs of sentences like (1a,b) are grammatically related. The grammar represents the two sentences as transformational variants of each other, analogous to the ways in which allophones and allomorphs are related to each other as variants of underlying abstract phonemes or morphemes. Assigning sentences a common deep structure also expresses the fact that the sentences are broadly synonymous with each other, specifically in that a given noun phrase will have the same semantic role in all.

Exercise

1. Create five pairs of sentences analogous to (1a,b), using the particles *up*, *out*, *over*, and *on*.
2. Draw the DS and SS trees for each pair.
3. What condition must be added to the particle movement transformation to correctly account for the following data?
 - a. The witness picked Fred out.
 - b. The witness picked out Fred.
 - c. The witness picked him out.
 - d. *The witness picked out him.
 (i.e., what condition must be added to ensure that the grammar does not predict that (d) is grammatical?)

A deep structure expresses what surface structures have in common and provides a basis for movement, deletion, and insertion. Transformations may create multiple surface structures from a single deep structure.

A simplified, overall model of a transformational grammar is:

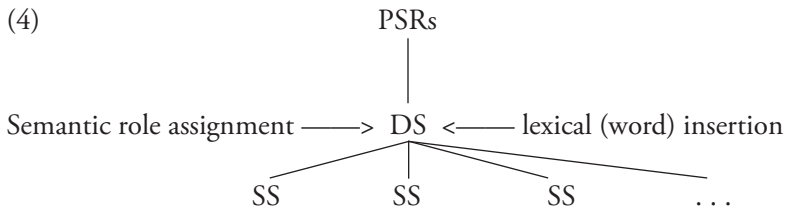

A note on the discourse functions of particle movement

Particle movement has no effect on the meaning of sentences to which it has applied. The semantic roles of the NPs in the sentences affected by PM are exactly the same as those in sentences unaffected. Are both sentence types freely interchangeable in all contexts then?

The answer to this should be clear from the exercise above. PM is generally optional but it *must* apply if the object is a pronoun. It seems plausible to assume that at least one factor in determining where to place the particle is the informational status of the object NP. If the NP represents old, known, or given information (and pronouns are typically in this category), then the particle moves to the right. If the NP represents new information, the particle is placed between V and NP. This is an example of the interaction between the syntactic and pragmatic components of the grammar.

Another factor, and probably the more important one, is the length of the object NP. The longer the NP the more likely the particle is to appear before, rather than after it, as the following sentences show:

- (5) a. He looked it up.
 b. He looked the number up.
 c. He looked his boss's number up.
 d. ?He looked the number that he had written on the back on a match book up.
 e. *He looked the number of the house where the cat that killed the rat that ate the malt lived up.
 f. He looked up the number of the house where the cat that killed the rat that ate the malt lived.

These examples illustrate the effect that length (or **weight**) can have on where a phrase can occur in a sentence.

Teaching phrasal verbs

We include this brief section primarily for teachers of ESL students because phrasal verbs can present them with significant difficulty, primarily because they are unusual in the languages of the world, but also because of their idiosyncratic syntax and idiomatic characteristics.

Phrasal verbs consist, as we have seen, of a verb and particle. Their semantics is often idiomatic; that is, the overall meaning of the phrasal verb cannot be determined from the typical meanings of the verb and particle, for example, the “provide care for” meaning of *look after*.

There are several syntactic classes of phrasal verbs for students and teachers to contend with:

- (6) a. Intransitive: *give in, move on* (Because these have no direct object, PM is impossible.)
- b. Transitive with optional PM: *bring back, look up, cut out*.
- c. Transitive with obligatory PM: *shut someone up, *shut up someone*.
- d. Transitive with prohibited PM: *do without something, *do something without*.

Good learners' dictionaries (e.g., Cambridge International Dictionary of English) provide useful expansions on this necessarily brief discussion.

ASSIGNMENT OF SEMANTIC ROLES

Topicalization

Phrases are assigned **semantic roles** by virtue of their grammatical relations within the sentence, specifically by virtue of their relation to a verb, preposition, or noun. Many, but by no means all, current theories make the assumption that an NP can be assigned *only one* semantic role in any clause. In the interests of simplicity we will adopt that assumption in this section.

We will assume also that, with very few exceptions such as expletive *it* and *there*, EVERY NP in a sentence must be assigned one but no more than one semantic role. Consider now the sentences:

- (7) a. Bill carried Mary.
- b. Mary, Bill carried.

In both of these sentences *Bill* is the Agent and *Mary* is the Theme. Note however that *Mary* occurs in two different positions in these sentences. In (7a) it occurs in the direct object position; in (7b) it is in what is known as the **topic position**. Speakers of English know that both of these sentences denote that Bill carried Mary. Let's assume that we have a rule whereby *carry* assigns Theme to its direct object in sentences like (7a). Must we now assume that we need another rule to account for the assignment of Theme to *Mary* in the topic position? Let's examine that possibility. Such a rule might say: *assign Theme to the NP directly to the left of the subject of the clause in which the assigning verb occurs*. However, when we examine some more data we can see that this becomes impossible.

- (8) a. Mary, Fred thinks that Bill carried.
 b. Mary, Susan believes that Fred thinks that Bill carried.
 c. Mary, I know that Susan believes that . . . that Bill carried.

Exercise

Insert 1, 2, and 3 further expressions of the form *NP Vs that* in the position occupied by the ellipses in (8c).

In each of the sentences of (8) *Mary* is understood as the Theme of *carried*. But we can insert as many *that*-clauses between *Mary* and *carried* as we wish. There is no principled bound to the number of such clauses. It follows that for an infinite number of sentences we would need an infinite number of rules to assign Theme to *Mary*. Clearly such a set of rules could not exist in anyone's mind. We must therefore find an alternative way of assigning a semantic role to all these different (but related) positions.

Rather than devise a complex set of rules that would directly assign Theme to *Mary* in all these positions, linguists have simplified the assignment process by assuming something like the following: *a verb such as carry assigns Theme to its **deep structure** direct object*. This phrase may afterwards be moved by transformations, though it will always be associated with its original, deep structure, position and therefore with its semantic role.

In support of this idea, note that we cannot put another NP into the object position and still interpret the resulting S as *Mary is carried by Bill*.

- (9) Mary, Bill carried Susie.

We can only interpret *Mary* in (9) as an addressee and not as a direct object. *Susie* has taken over that role. Because *Mary* can no longer be associated with the DO position it cannot be interpreted as Theme. So the deep structure position with which a moved phrase is associated and from which it derives its semantic role must be empty.

Let's now think about the position that the topicalized phrase occupies in surface structure. There are various possibilities. One is that topicalization inserts the topicalized phrase directly under S. However, we will introduce a new node, **COMP** (for **COMPLEMENTIZER**), which requires a special phrase structure rule to generate it:

- (10) S' —> COMP S (S' is pronounced as S-bar)

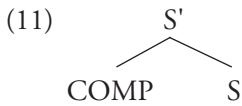

We will assume that topicalization inserts the moved phrase into COMP. The surface structure of (7b) would therefore be represented as:

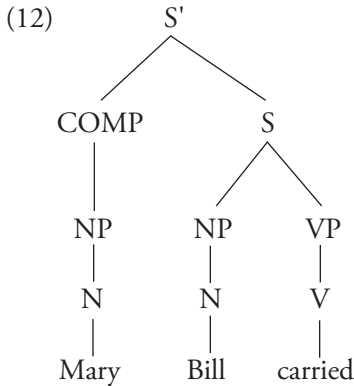

COMP is a position outside of S that occurs in every S'. It is never assigned a semantic role directly. A phrase in COMP acquires its semantic role by virtue of its association with some deep structure position. This association is represented by the transformation that moves the phrase. As every NP must be assigned a semantic role, it follows that there can be no NP in COMP in deep structure. We will call positions that cannot be assigned a semantic role directly in DS **non-argument positions**. This is often abbreviated as **A'** (read A-bar) in the literature. **Argument (A-) positions** are those positions within S to which semantic roles *may* be assigned in deep structure. They include, as you no doubt guessed, subjects, objects, and objects of prepositions. We will discover later that while these positions may be assigned a semantic role, they occasionally are not. So topicalization moves a phrase from an A position to which a semantic role has been assigned to an A' position.

Besides moving an NP, as in the examples above, topicalization can move any phrase to COMP:

- (13) a. *Mary*, I like. (NP topic)
 b. *Into the valley of death*, I will not go. (PP topic)
 c. *Intelligent*, he is not. (AP topic)
 d. I said that Fred would go home, and *go home* he will. (VP topic)

- e. *Quickly* she left. (AdvP topic)

Exercise

1. Draw the deep structure and surface structure trees for each sentence in (13).
 2. What PSRs created the DSs?
 3. Describe the changes that the topicalization transformation makes to the DS as it changes it into the SS.
-
-

Discourse functions of topicalization

Every native speaker of English knows that topicalized and non-topicalized sentences express essentially the same message: the semantic roles of the various NPs in the sentences are unchanged by the movement. There is nonetheless a difference between the two forms. The non-topicalized is a more general-purpose construction than the topicalized, which we would use only in special contexts.

The most typical reaction speakers of English have upon hearing sentences such as:

- (14) The forks, you put on the left.

is that the entity or entities referred to by the topic NP, *the forks*, have already been introduced (directly or indirectly) into the discourse. So (14) might occur as the answer to:

- (15) Which side do I put the forks on?

A second and closely related use of topicalized sentences is to refer to an entity that is a member of a set of related entities that has already been introduced into the discourse. A typical other sentence to go along with (14) might be:

- (16) and the knives you put on the right.

Knives and forks are members of the set of silverware items, and if you came upon a conversation in which (14) was the first sentence you heard,

you could reasonably assume that the speakers had already mentioned silverware, and one speaker was now listing the individual members of the silverware set and telling a child (for example) where each one goes in a place setting. So, the NP in topic position can refer to a member of a set of items that has already been introduced into the discourse.

Just to show you that we're not simply making this up out of hot air, consider the following authentic example.

- (17) He'd have been lucky to get thirty percent . . . , **sixty one, Snow gave him** (Le Carré 1962/1980: 74)

Here the topic is a student's grade. Thirty and sixty one percent are members of the set of possible grades. Sixty one can be topicalized because it is a member of the already mentioned set and contrasts with thirty.

To sum up our discussion of topicalization: topicalization moves any phrase from its position within S to the COMP position. The moved phrase retains the semantic role it was assigned at deep structure. The old position may not be filled with another phrase. No morphological changes occur either to the moved phrase or to other elements of the sentence. Topicalization is used to refer to entities that are members of sets or lists that have already been introduced into the discourse (Ward and Birner 2001).

Subject-auxiliary inversion

As we noted in our chapter on Basic Clause Patterns, the order of subject and first auxiliary verb is reversed in yes/no questions (18a-f), and sentences that begin with negative adverbs such as *rarely* (19):

- (18) a. Can I have another go?
b. Have you taken the trash out?
c. Are you leaving now?
d. Will you be OK?
e. Were you hurt in the accident?
f. Could I have forgotten my keys again?
- (19) Rarely have I seen such a magnificent sunset!

As you recall, the immediate constituents of S are NP AUX VP. Using these as our base, we can relate a yes/no question to its declarative counterpart by assuming that both have the same deep structure (NP AUX VP), and that there is a transformation (called **Subject/Auxiliary Inversion (SAI)**) that moves AUX to the left of the subject in the question (AUX NP VP).

We will assume that a moved AUX is **adjoined to S** rather than just inserted directly under it. Adjunction to S involves first creating a second S node above the original one and then inserting AUX (or more generally the adjoined phrase) under the newly created node. SAI applies to (20a) to give (20b):

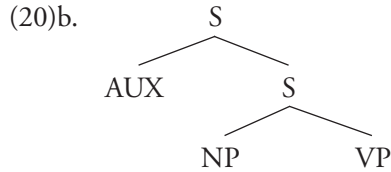

The technical reasons for adjunction need not detain us here.

Exercise

Draw the deep and surface structure trees for the sentences in (18) and (19). Describe what the SAI transformation does to the DS tree to create the SS tree.

In our chapter on Basic Clause Patterns, we showed that auxiliary verbs are optional and that when they occur they do so in the order:

- (21) (Modal) (Perfective *have*) (Progressive *be*) (Passive *be*)

SAI affects only the first verb in the sequence, regardless of which it is. In fact, we will assume that only the first auxiliary verb is actually in the AUX position when SAI applies. Later in this chapter we discuss the positions of the other verbs. SAI creates sentences such as:

- (22) a. Must you leave?
 b. Has she left?
 c. Is she leaving?

Exercise

Draw tree diagrams of the deep and surface structures of sentences (22a,b,c) above.

If the basic sentence has no auxiliary verb, then we put a form of *do* into the first auxiliary slot (**Do Insertion** or **Do Support**), transfer the tense from the main verb, and apply SAI to it:

- (23) a. He works out really hard.
 b. He does work out really hard.
 c. Does he work out really hard?
 d. *Works he out really hard? (cf. German, earlier forms of English, Spanish)

Exercise

What is the DS of (23a, b, c)? Hint: all three have the same DS.

Wh-movement

Relative clauses frequently begin with a *wh*-phrase. Relative *wh*-phrases may be NPs (*which*), PPs (*to whom*), and APs (*how tall*). *Wh*-phrases get moved to COMP from a deep structure position within a clause, as in the relative clause (italicized) below:

- (24) The person *to whom you spoke* is no longer here.

The deep structure of this relative clause is:

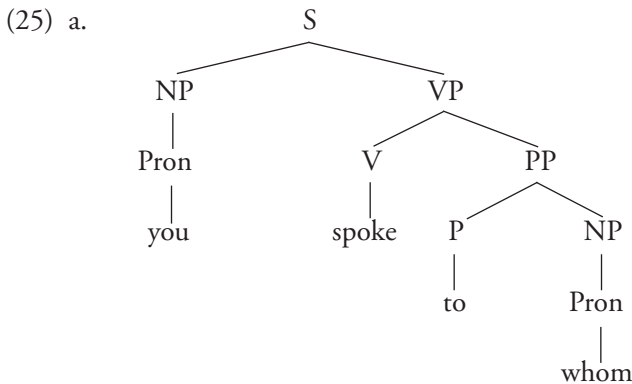

The *wh*-phrase is moved into a COMP by a transformation called **wh-movement**:

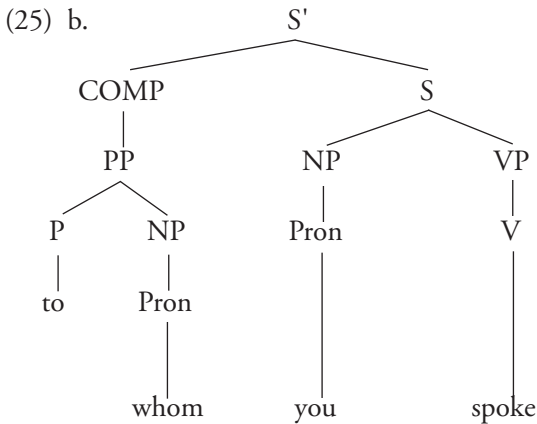

Exercise

1. Describe what wh-movement does.
 2. Draw the DS and SS trees for the following two bracketed relative clauses: *The book [which you wrote], The man [whom you spoke to]*.
-
-

Wh-questions

Wh-questions, such as *Who will you invite to the dance?*, which ask for a phrase as a reply, involve two transformations: subject auxiliary inversion and wh-movement. Let's assume that SAI occurs before wh-movement. The deep structure of this question is:

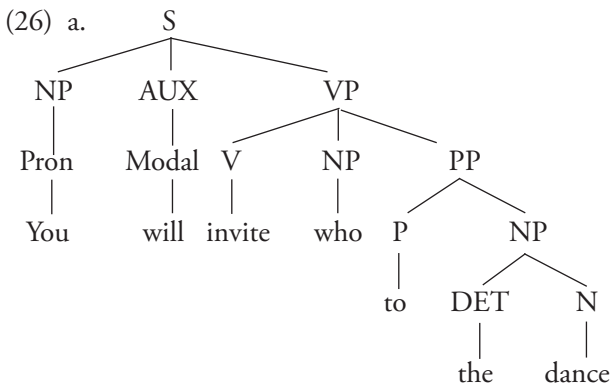

Applying SAI to this creates:

(26)b.

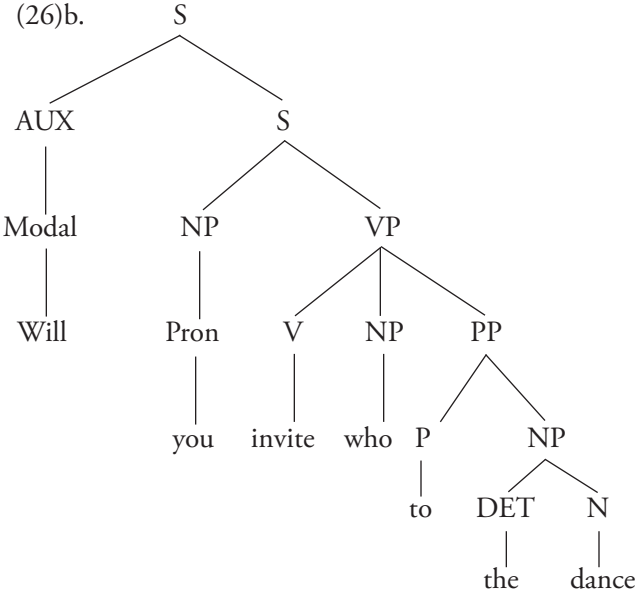

And applying wh-movement to this yields:

(26)c.

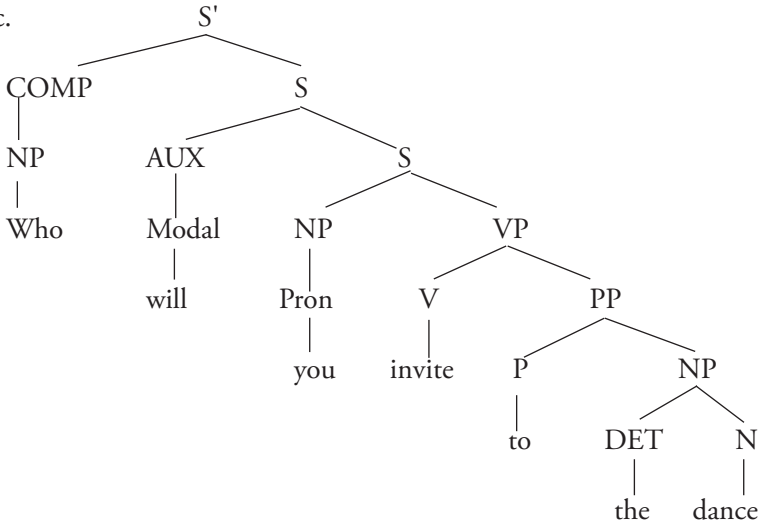

Wh-movement may also occur in indirect questions without SAI:

- (27) We wondered [what Nancy would say].

Clearly, one or more transformations can apply to derive a sentence's surface structure from its deep structure.

DELETION

Besides moving them around in sentences, transformations may also delete phrases. "Understood" elements in clauses or sentences are typically regarded as having been deleted by a transformation. We briefly examine two deletion rules: Imperative Subject Deletion and VP Deletion.

Imperatives

- (28) a. Get out now!
b. Behave yourself! (cf. *Behave herself!)
c. A: Do it! B: No. You do it!

There are reasons to believe, however, that imperatives have deep structure subjects. First, English sentences in general have subjects, and it would be odd if one class of sentences lacked them. Second, and much more convincingly, imperatives interact with reflexive pronouns in ways that would be hard to explain if they had no subject. Consider:

- (29) a. Bill shaved himself.
b. You shaved yourself.
c. I shaved myself.
d. They shaved themselves.
e. You shaved yourselves.
f. We shaved ourselves.
g. *You shaved myself/himself/herself/themselves/ourselves.

A reflexive pronoun in the direct object position must agree in person, number, and gender with the subject of its clause. That is, the form of the reflexive pronoun is dependent upon the grammatical characteristics of the subject. Clearly, for this to be the case there must be a subject for it to depend on. Bearing this in mind, consider:

- (30) a. Shave yourself/yourselves!

- b. *Shave myself/himself/herself/themselves/ourselves.

We can explain this pattern of data by assuming that the deep structure of (30a,b) is:

- (30) c. You shave yourself.

Because the only reflexive that can occur here is the second person reflexive (either singular or plural), the (understood) subject of a reflexive imperative must be *you*. But the subject *you* can be, and generally is, deleted—by a transformation called **Imperative Subject Deletion**.

The AUX of imperative sentences also seems to be special. Non-imperative AUX phrases may contain a modal; an imperative AUX may not, even though an imperative sentence may contain other auxiliary verbs, as the following show:

- (31) a. Close the door!
 b. *Must close the door!
 c. *Will eat your vegetables!
 d. Have the dishes washed when I return!
 e. Be studying when I return!
 f. Be gone by daybreak!

If we assume that the AUX phrase can be occupied by either a modal or a marker that indicates that the sentence is an imperative, then Imperative Subject Deletion will correctly capture the facts. Consequently the deep structure of *Close the door!* is:

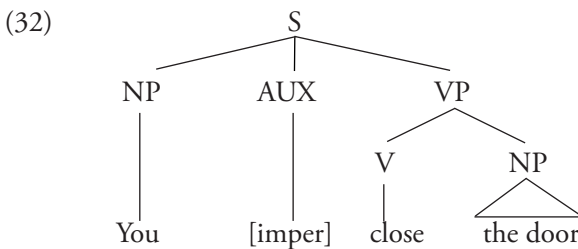

Exercise

Which applies first, Imperative Subject Deletion or the rule that checks that a reflexive pronoun has an appropriate antecedent? Why?

A note on the pragmatics of imperatives

Imperatives are traditionally thought of as the form used for giving orders. Recent research suggests that there is more to be said about them than this, and that they raise interesting issues of language use. Fundamentally, a speaker using an imperative assumes that the addressee will do what the sentence expresses. However, studies of politeness suggest that speakers must concern themselves with their addressee's **face**, that is, their public self-image and desire to be unimpeded (Brown and Levinson 1987). Speakers must be careful not to deny aspects of an addressee's self-image or unreasonably impose upon him or her. Imperatives can only be politely used when they do not violate aspects of an addressee's face.

Addressees can be assumed to be willing to cooperate with speakers without loss of face under several types of circumstances. First, if the speaker has the authority to order the addressee to carry out the act expressed by the imperative. Second, if the addressee can be assumed to want to carry out the act. For example, recipe directions are expressed in the imperative, at least partly because their readers may want to carry out the directions. Similarly, people who have asked for directions can be assumed to want to carry them out:

- (33) Take College Blvd. south for three blocks, then turn right on Horsetooth, . . .

Imperatives are polite also in (good) wishes:

- (34) a. Get well soon!
b. Have a nice day!

Or in offers:

- (35) a. Let me take care of that.
b. Have another piece of cake.
c. Come on in.

Or in warnings:

- (36) Watch out!

We hope you remembered that the grammatical categories indicative, interrogative, and imperative belong to the category of grammatical mood.

Exercise

1. From the point of view of the discussion of face, explain why the use of the imperative in the “wish” *Go to hell!* is impolite.

2. The following (slightly adapted) recipe is for a beet salad, taken from *Saveur* (March 2006: 40). Like most recipes it consists of a list of ingredients followed by a list of instructions on what to do with them. And like most recipes, the instructions are expressed in the imperative mood. (a) Identify all the imperative clauses. (b) Write the instruction section below using a mood other than the imperative. (c) Why do you think that the typical mood of the instruction section of recipes is the imperative? (d) What other changes must you make? Why?

FOR THE BEETS:

3 medium beets (1 lb.), trimmed

Salt

¼ cup extra-virgin olive oil

2 tbsp. balsamic vinegar

Salt and freshly ground black pepper

For the beets: Put beets into a medium pot, cover with salted water, and bring to a boil over high heat. Reduce heat to medium-low and simmer until tender, 1½-2 hours. Remove beets from pot, let cool slightly, then peel and cut into 1” chunks. Toss beets, oil, and salt and pepper to taste in a bowl.

VP deletion

Yet another deletion rule deletes the VP of a sentence when it is identical to the VP of a preceding sentence, as in:

(37) a. Fred can go to the movies, and Mary can too.

We understand (37a) as:

(37) b. Fred can go to the movies, and Mary can [go to the movies] too.

If we take (37b) as representing the deep structure of (37a) and posit a transformation that deletes the VP of a second clause (bracketed in 37b) when it is identical to the VP of an earlier clause, then we will have account-

ed for our understanding of these two sentences. In general, deletion can take place when it is possible to figure out easily from the context, linguistic or non-linguistic, just what has been deleted. **Deletion under identity** as in (37a) is a typical case in which the prior linguistic context allows the recovery of the deleted elements.

VP deletion is more complex than we have represented it. When we examine it more closely we discover some interesting things about the structure of the VP, as the following sentences show:

- (38) a. John must have been learning Spanish, and Fred must have been learning Spanish too.
 b. . . . and Fred must have been too.
 c. . . . and Fred must have too.
 d. . . . and Fred must too.
 e. . . .?and Fred, too.

In sentences (38b-d), respectively, we have deleted [V NP], [been V NP], [have been V NP]. In general, transformations operate on phrases rather than arbitrary strings of words, and if we assume that this must be the case, then each of the sequences [V NP], [been V NP], and [have been V NP] must be a phrase. It follows that VP is composed of several levels of phrase structure, and that VP deletion may apply to any of these levels:

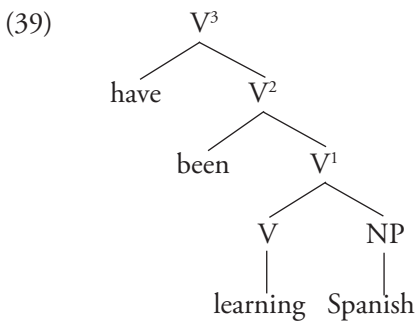

Some discourse functions of deletion

The fundamental function of deletion is to make processing discourse easier for both its producers and its audiences. The producer has to say or write less; the audience has less to hear and process. Our minds derive inferences (jump to conclusions) more rapidly than they process linguistic input, so deletion takes advantage of that difference in processing speed by reducing linguistic input and allowing the mind to fill in the blanks. And sometimes,

too, to say less is to say more . . .

INSERTION

There are clause types which, under certain circumstances, require the insertion of apparently superfluous expressions. We briefly discuss clauses whose subject is non-referential *there*.

Existential there sentences

English contains pairs of sentences such as the following, which, like active and passive pairs, are essentially synonymous, but with some subtle differences:

- (40) a. A unicorn is in the garden.
b. There is a unicorn in the garden.

The second differs from the first in that its subject contains “existential *there*” (which does not refer to a specific location), and the phrase that corresponds to the subject of the first sentence (*a unicorn*) occurs after the verb *be*. How are we to represent the similarities and differences between such sentences?

As you have probably guessed at this point, a modern linguist is likely to say that they are transformationally related. That is, they both have deep structures similar to (40a), but the derivation of (40b) involves a transformation that moves the subject phrase into the VP and another that inserts *there* into the vacated subject slot.

What gives us the right to say that the NP that follows the verb is the subject in existential *there* sentences, when subjects generally occur before their verbs in English clauses? Normally English verbs agree with their surface structure subjects. In existential *there* sentences, however, the verb agrees with the NP that follows it in surface structure:

- (41) a. There are unicorns in the garden.
b. *There is unicorns in the garden.

(41b) is unacceptable in written or formal English, although its contracted form, (42), is acceptable in informal, colloquial varieties:

- (42) There's unicorns in the garden.

Some discourse functions of existential there sentences

No doubt you noticed that the deep structure subject of existential *there*

sentences is typically an indefinite NP. Indefinite NPs typically represent information that is assumed to be new to the audience, and typically is placed later in sentences. Old information is generally expressed early in a sentence, often in the subject. Topics are generally old information, and so are frequently expressed in the subject phrase. Obviously, discourse must have ways of introducing new topics, and existential *there* sentences, by placing the new topic after the verb, are a natural way of accomplishing this. They are also used to assert the existence of entities and to summarize information (Huckin and Pesante 1988).

Exercise

1. Identify the DS and SS of:
 - a. There is a house in New Orleans.
 - b. There is a god.
 - c. There may have been water on Mars.

 2. Apply *there* insertion to:
 - a. A solution is available.
 - b. A skeleton was in the closet.
 - c. Pilgrims may have been here in the past.
-
-

PASSIVE

We introduced the passive voice in various other chapters, so here we begin with a functional description:

(43) Subject Be Ven (Agentive phrase)

Passive sentences include some form of the verb *be* followed by a verb in its past participle form. Passives may include an agentive (*by*) phrase. Formally they consist of:

(44) NP AUX [_{VP}V+en (by NP)]

For example:

- (45) a. The children were fed by the baby-sitter.
 b. The pretzels were eaten by the mice.
 c. The children were fed.

- d. The pretzels were eaten.

As a general rule, passive sentences have active counterparts, although a missing agent phrase may have to be expressed as an indefinite pronoun:

- (46) a. The baby-sitter fed the children.
 b. The mice ate the pretzels.
 c. Someone fed the children.
 d. Someone/something ate the pretzels.

The active subject corresponds to the NP in the passive *by*-phrase, and the passive subject corresponds to either a direct or indirect object in the active:

- (47) a. The package was sent to Amanda.
 b. Amanda was sent the package.

Or occasionally to the object of a preposition:

- (48) My bed has been slept in.

In the kind of analysis we are using here, the deep structures of synonymous active and passive sentences are taken to be identical, and the passive transformation (a) creates the *by*-phrase, (b) moves the subject NP into it, (c) moves the direct object NP into the now-vacant subject position, (d) inserts the verb *be*, and (e) changes the morphology of the verb to the passive participle form. The deep structure of (45b) and (46b) is:

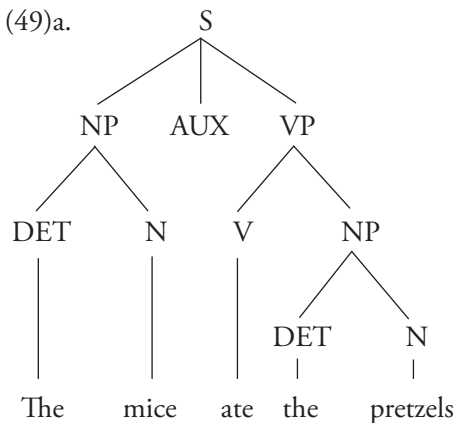

(46b) results when the passive transformation does not apply to (49a); (45b) results when it does. The surface structure of (45b) is:

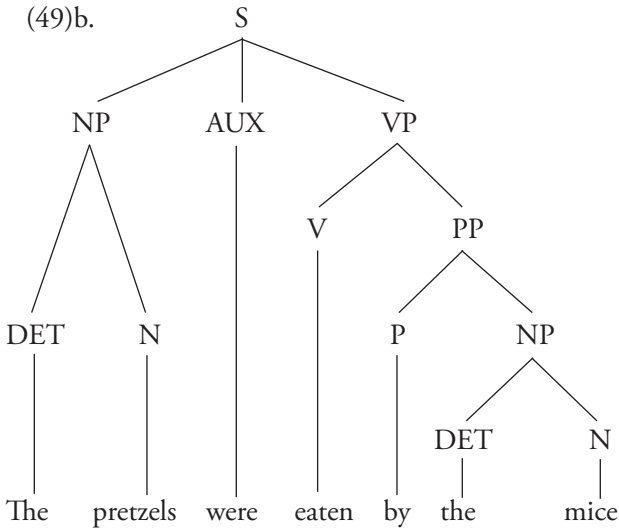

A note on the use of passive sentences

Style manuals and many school grammars and composition textbooks advise students (and writers generally) to avoid the passive. However, research has demonstrated that student writers use the passive less often than expert writers (Garvey and Lindstrom 1989). It would appear therefore that what students need to learn is how to use the passive appropriately, a piece of advice that applies to all sentence types.

There are two major traditional objections to passives. First, they are alleged to be deceitful: they can and often do omit reference to the agent responsible for an event. Second, because they begin with an NP whose semantic role is not an Agent and include a form of *be*, they are alleged to be “weak.”

In response to the first objection we say that omitting pieces of sentences is not something that only passives can do. Many if not all sentence types can. So in this regard writers need to decide just what information must be presented and what can be omitted from a text. This is a matter of audience, not just of grammar.

In response to the second objection, most languages of the world have constructions that correspond to the English passive. It would be most unlikely for these constructions to have developed and been retained if they were not of considerable value. What they do is allow the information rep-

resented in the active to be restructured. Because old, familiar, or given information tends to be placed before new information so that it can be easily connected with its prior context, passive allows old information that would be placed later in the corresponding active to be appropriately placed earlier. Additionally, **truncation** (deletion) of the agentive phrase from a passive allows speakers and writers to efficiently avoid repeating information that may be readily derivable from the context. Omission of the agentive phrase also allows scholars a polite way to criticize each other (Meyers 1989).

In fact, all languages provide means to allow information to be restructured. In English alone we have at least the following:

- (50) a. The mice ate the pretzels. (Active)
b. The pretzels were eaten by the mice. (Passive)
c. The pretzels were eaten. (Truncated passive)
d. The pretzels, the mice ate. (Topicalization)
e. What ate the pretzels were the mice. (Wh-cleft)
f. What the mice ate were the pretzels. (Wh-cleft)
g. The mice are what ate the pretzels. (Reversed wh-cleft)
h. It was the mice that ate the pretzels. (It-cleft)
i. It was the pretzels that the mice ate. (It-cleft)
j. It was that the mice ate the pretzels. (Inferentials)
k. Not that the mice ate the pretzels. (*Not that* sentence)
l. The thing is that the mice ate the pretzels. (*Thing* sentence)

The order in which information is deployed in a sentence depends upon a number of factors, including whether it is already familiar to the audience, whether it is topical, and whether the speaker/writer wishes to give it special prominence. Each of the constructions illustrated just above has its own idiosyncratic textual effects, and so must be used in appropriate contexts. We will discuss a number of these in our chapter on Multi-Clause Sentences.

Exercise

1. Draw both the DS and SS trees of *The baby-sitter fed the children* and *The children were fed by the baby-sitter*.
 2. Find five passive sentences in an authentic text. Replace them with their active counterparts, if possible. Then try to articulate why the author used the passive instead of the active in each case.
-
-

REFERENCES AND RESOURCES

- Brown, Penelope and Stephen Levinson. 1987. *Politeness: Some Universals in Language Usage*. Cambridge, UK: Cambridge University Press.
- Carnie, Andrew. 2007. *Syntax: A Generative Introduction*. Oxford, UK: Blackwell.
- Chomsky, Noam. 1964. *Aspects of the Theory of Syntax*. Cambridge, MA: MIT Press.
- Culicover, Peter. 1976. *Syntax*. New York: Academic Press.
- _____. 1982. *Syntax*. 2nd ed. New York: Academic Press.
- Garvey, James J. and David H. Lindstrom. 1989. Pros' prose meets the Writers' Workbench. *Computers and Composition* 6(2): 81-109.
- Huckin, Thomas and L. Pesante. 1988. Existential *there*. *Written Communication* 5(3): 368-391.
- LeCarré, John. 1962/1980. *A Murder of Quality*. New York: Bantam.
- Meyers, Greg. 1989. The pragmatics of politeness in scientific articles. *Applied Linguistics* 10(1): 1-35.
- Radford, Andrew. 1981. *Transformational Syntax: A Student's Guide to Chomsky's Extended Standard Theory*. Cambridge, UK: Cambridge University Press.
- _____. 1988. *Transformational Grammar: A First Course*. Cambridge, UK: Cambridge University Press.
- _____. 1997a. *Syntax: A Minimalist Introduction*. Cambridge, UK: Cambridge University Press.
- _____. 1997b. *Syntactic Theory and the Structure of English: A Minimalist Approach*. Cambridge, UK: Cambridge University Press.
- Ward, Gregory and Betty J. Birner. 2001. Discourse and information structure. In Deborah Schiffrin, Deborah Tannen and Heidi E. Hamilton (eds.) *Handbook of Discourse Analysis*. Oxford, UK: Blackwell.

GLOSSARY

ARGUMENT: any expression syntactically required by another expression, e.g., the direct object is an argument of a transitive verb.

ARGUMENT POSITION: a deep structure position to which a semantic role may be assigned by a verb, preposition, or other semantic role assignor. See **NON-ARGUMENT POSITION**.

COMPLEMENTIZER: an expression that introduces a subordinate clause, e.g., *that*; the non-argument, structural position (**COMP**) that such an expression occupies, viz immediately under S' (S-bar).

DEEP STRUCTURE: abstract level of syntactic/structural representation posited by transformational grammar and created by phrase structure rules, into which lexical insertion rules place lexical items, and which transformational

rules alter by moving, deleting, or inserting items.

DELETION: the removal of parts of a linguistic expression by transformation, especially when the deleted elements can be readily inferred from the context.

DO INSERTION/SUPPORT: transformational rule that places a form of the auxiliary *do* into clauses that include no other auxiliary, to indicate emphasis or negation or to allow subject auxiliary inversion.

EXISTENTIAL THERE: use of the form *there* in simple *be* sentences with indefinite subjects that denote the existence of the subject's referent, e.g., *There is a house in New Orleans*.

FACE: our expectation that others will respect our public self-image (positive face) and desire not to be imposed upon (negative face); concept in **POLITENESS** theory.

IMPERATIVE SUBJECT DELETION: transformational rule that deletes the deep structure subject of imperative clauses (typically argued to be *you*).

MOVEMENT: class of transformational rules designed to explain why expressions that are not in their deep structure position, are interpreted as if they were. See **SUBJECT AUXILIARY INVERSION**, **TOPICALIZATION**, **WH-MOVEMENT**.

NON-ARGUMENT POSITION: a structural position to which a semantic role may not be assigned directly by a verb, preposition, or other semantic role assignor, e.g., the **COMP** position.

PARTICLE: minor uninflected part of speech, including words such as *up*, *over*, which can also be used as adverbs and prepositions, and which combine with verbs to create **PHRASAL VERBS**.

PASSIVE VOICE: one of many marked English sentence constructions that allow the redistribution of information in clauses; contrasts with the active voice in that it includes a form of *be* associated with a past participle verb, its subject typically corresponds to an active object, and the object of its *by* phrase (if it has one) corresponds to the active subject.

PHRASAL VERB: idiomatic verbal unit composed of verb and particle, e.g., *look up*, *hook up*.

PHRASE STRUCTURE RULES (PSRS): rules posited by transformational grammar that create deep structure trees.

POLITENESS: theory designed to account for the use of expressions that orient to an interlocutor's **FACE**.

SEMANTIC ROLES: set of meaning relations between expressions in sentences, especially between verbs and noun phrases, e.g., Agent, Theme, etc.

SUBJECT AUXILIARY INVERSION (SAI): movement transformation that takes the first auxiliary verb in a clause and moves it to the left of the clause's subject; applies in interrogatives.

SURFACE STRUCTURE: level of syntactic/structural representation posited by transformational grammar and derived from deep structure by applying **TRANSFORMATIONAL** rules.

TOPICALIZATION: one of many marked English sentence constructions that allow the redistribution of information in clauses; places to the left of the subject a phrase that would normally occur elsewhere in a sentence.

TRANSFORMATION/TRANSFORMATIONAL RULE: device posited by transformational grammar that transforms deep structures into surface structures by moving, deleting, or inserting expressions.

TRUNCATION: the deletion of the agentive/*by*-phrase of a passive sentence.

WH-MOVEMENT: transformation that moves a *wh*-phrase into COMP.

WH-QUESTION: interrogative sentence form in which *wh*-movement has applied.